

OCULUS VIS-NIR Hyperspectral Payload For CUBESAT

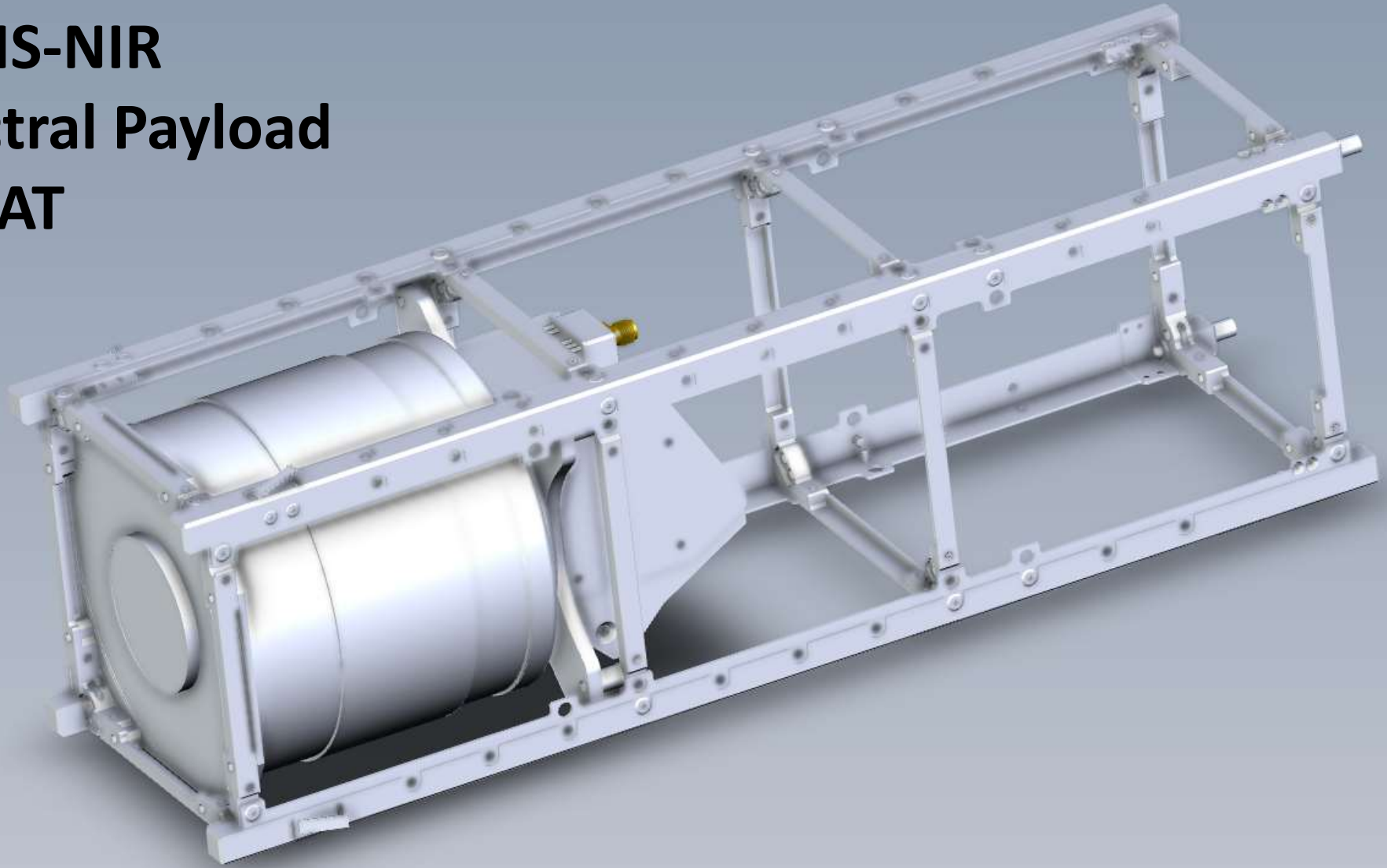

Enquiries: a.paglialunga@superelectric.it



OCULUS VIS-NIR Hyperspectral Payload



TECHNICAL SPECIFICATIONS

Spectral range: 340-840nm
(option: 640-1050nm)

Spectral Resolution: 15 nm

Spectral Bands: 256

A/D resolution: 16 bits

FOV x: 0,02°

FOV y: 0,005°

DIMENSIONS:



CUBESAT UNITS: 2

WEIGHT: 980 g

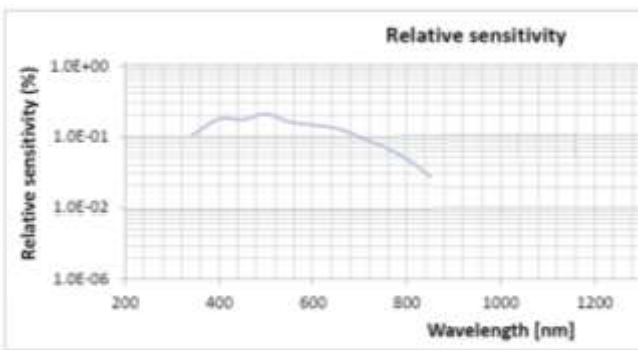

Reliability test

Temperature cycle : -20°C to +70°C, 30minutes each

Representative 1pc

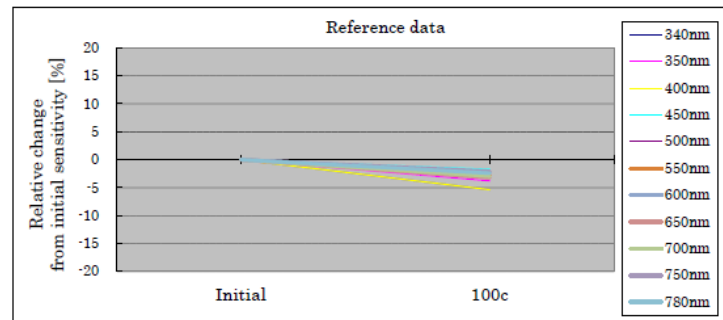
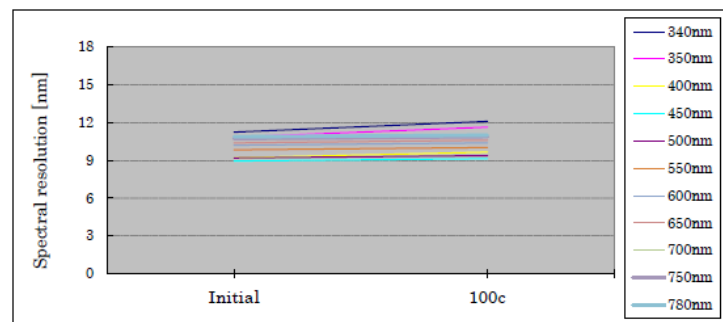
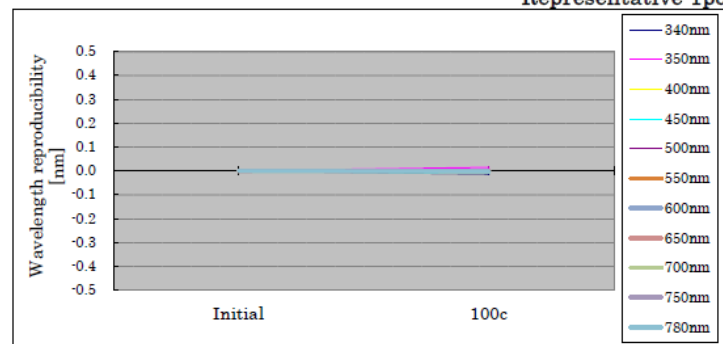

Reliability test

Vibration : 100 to 2000Hz, 200m/s²,

XYZ directions, 4minutes, 4times each

Representative 1pc

